

	68~71	Gobo17
	72~113	Rotate forward (Fast -- slow)
	114~117	stop (white)
	118~159	Rotate reverse (Slow -- fast)
	160~166	Gobo2, shaking slow to fast
	167~172	Gobo3, shaking slow to fast
	173~179	Gobo4, shaking slow to fast
	180~185	Gobo5, shaking slow to fast
	186~191	Gobo6, shaking slow to fast
	192~198	Gobo7, shaking slow to fast
	199~204	Gobo8, shaking slow to fast
	205~211	Gobo9, shaking slow to fast
	212~217	Gobo10, shaking slow to fast
	218~223	Gobo11, shaking slow to fast
	223~230	Gobo12, shaking slow to fast
	231~236	Gobo13, shaking slow to fast
	237~243	Gobo14, shaking slow to fast
	243~249	Gobo15, shaking slow to fast
	250~255	Gobo16, shaking slow to fast

17R BEAM MOVE HEAD LIGHT[1B]

USER MANUAL

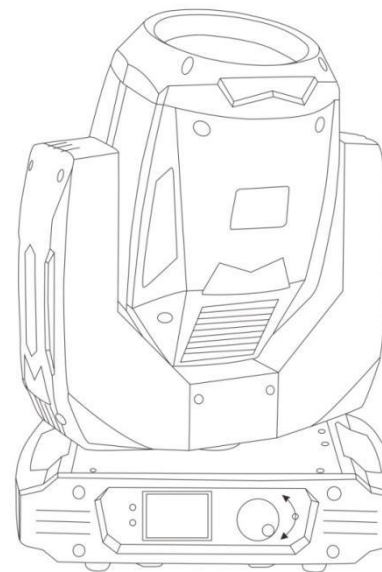

JIA-J473

JIA LIGHTING

Please read over this manual before operation the light

CONTENTS

Chapter 1	Installation and attention.....	3
1.1	Maintenance.....	3
1.2	Statement.....	3
1.3	Safety Precaution.....	3
1.4	Product Instruction.....	4
1.5	Cable connection (DMX)	5
1.6	Rigging (Optional).....	5
Chapter 2	Panel operation.....	8
2.1	Brief.....	8
2.2	Operation.....	9
2.2.1	Operate light with touch or encoder button.....	9
2.2.2	Parameter value setting.....	9
2.2.3	Boolean parameter setting.....	10
2.2.4	Sub Menu (Parameter)	10
2.3	Operation and parameter instruction.....	11
2.3.1	ADDR--> Address: Set DMX Address.....	12
2.3.2	MODE--> WorkMode: Set Light work mode.....	12
2.3.3	DISP-->DISPLAY: Set display.....	11
2.3.4	TEST--> TestMode.....	10
2.3.5	ADVA-->Advanced: Set light run parameter.....	9
2.3.6	STAT-->Status: View status.....	7
Chapter 3	Channel description.....	6
3.1	Channel table.....	错误!
	未定义书签。	
3.2	Channel Detail.....	4
3.2.1	COLOR.....	4
3.2.2	GOBO.....	2

3.2.2 GOBO

CH NO.	NAME	VALUE	FUNCTION
CH4	GOBO	0~3	WHITE
		4~7	Gobo1
		8~11	Gobo2
		12~15	Gobo3
		16~19	Gobo4
		20~23	Gobo5
		24~27	Gobo6
		28~31	Gobo7
		32~35	Gobo8
		36~39	Gobo9
		40~43	Gobo10
		44~47	Gobo11
		48~51	Gobo12
		52~55	Gobo13
		56~59	Gobo14
		60~63	Gobo15
64~67	Gobo16		

	69-72	COLOR8
	73-76	COLOR8 + COLOR9
	77-81	COLOR9
	82-85	COLOR9 + COLOR10
	86-89	COLOR10
	90-93	COLOR10 + COLOR11
	94-98	COLOR11
	99-102	COLOR11 + COLOR12
	103-106	COLOR12
	107-110	COLOR12 + COLOR13
	111-115	COLOR13
	116-119	COLOR13 + COLOR14
	120-123	COLOR14
	124-127	COLOR14 + WHITE
	128-255	Rotate forward (Fast -- slow)

1.1 Maintenance

- To reduce the risk of electrical shock or fire, do not expose this unit to rain or moisture.
- Intermittently using will extend this item's service life.
- Please clear the fan ,fan net , and optical lens in order to keep good work state. Do not use the alcohol or any other organic solvent to wipe the shell.

1.2 Statement

The product has perfect performance and integrity packing. All users should be strictly complying with the warning and operating instructions as stated. Or we aren't in charge of any result by misusing. Any damage resulting by misuse is not within the Company's warranty. Any fault or problem caused by neglecting the manual is also not in the charge of dealers.

Note: All information is subject to change without prior notice.

1.3 Safety Precaution

- In order to guarantee the product's life, please don't put it in the damp places or even the environment over 60degrees.
- Always mount this unit in safe and stable matter.
- Install or dismantle should operate by professional engineer.
- Using lamp, the change rate of power voltage should be within±10%, If the voltage is too high, it will shorten the light's life; If it's not enough, will influence the effect.
- Please restart it 20 minutes later after turning off light , until full-cooling. Frequent

switching will reduce the life span of lamps and bulbs; intermittent using will improve the life of bulbs and lamps.
 In order to make sure the product is used well, please read the Manual carefully.

1.4 Product Instruction

- lamp: Philips MSD Platinum 17R or YODN 17R (life:2200 hours Color temperature: 8000K)
- Channel mode:20 DMX512 Channel
- Pan scan: 540°(16bit) Electric correction
- Tilt scan: 270° (16bit) Electric correction
- Amazing dot matix, four tact switch, 180° turning show
- Color wheel: one color wheel, 14 kinds of color chips in one color wheel
- Gobo: 17 gobos
- Effect Wheel: Rotation eight prism, effect move , frost
- 0-100% mechanical dimming, mechanical dimming and free dimming available.
- strobe macro control available.
- Lens optical system achanical fouce .beam angle 0~4°
- Over heat protection
- Power Input: 100-240V, 50/60Hz
- Power Dissipation: 450
- IP level :IP20
- Magnetic ballast and AC/Dc power supply

3.2 Channel Detail

3.2.1 COLOR

CH NO.	NAME	VALUE	FUNCTION
CH1	COLOR	0-4	WHITE
		5-8	WHITE+COLOR1
		9-12	COLOR1
		13-17	COLOR1 + COLOR2
		18-21	COLOR2
		22-25	COLOR2 + COLOR3
		26-29	COLOR3
		30-34	COLOR3 + COLOR4
		35-38	COLOR4
		39-42	COLOR4 + COLOR5
		43-46	COLOR5
		47-51	COLOR5 + COLOR6
		52-55	COLOR6
		56-59	COLOR6 + COLOR7
60-63	COLOR7		
64-68	COLOR7 + COLOR8		

	CH7	PRISM 2	0-63	White
			64-127	PRISM4
			128-191	PRISM5
			192-255	PRISM6
	CH8	Colors	0-127	No frost
			128-255	Colors
	CH9	FOUSE	000-255	FOUSE (far to near)
	CH10	PAN	000-255	0~540°
	CH11	PAN FINE	000-255	
	CH12	TILT	000-255	0~270°
	CH13	TILT FINE	000-255	
	CH14	NULL		
	CH15	RESET	0~127	none
			128~255	Reset light (stay over 3 second)
CH16	LAMP	0~25	none	
		26~100	Turn off lamp (stay over 3 second)	
		101~255	Turn on lamp (stay over 3 second)	
Extend 20CH	CH17	P/T SPEED	0~255	PAN & TILT SCAN SPEED FAST TO SLOW
	CH18	COLOR SPEED	0~255	COLOR SPEED FAST TO SLOW
	CH19	FOCUS SPEED	0~255	FOCUS SPEED FAST TO SLOW
	CH20	GOBO SPEED	0~255	GOBO SPEED FAST TO SLOW

1.5 Cable connection (DMX)

Use a cable conforming to specifications EIA RS-485: 2-pole twisted, shielded, 120 Ohm characteristic impedance, 22-24 AWG, low capacity. Do not use microphone cable or other cable with characteristics differing from those specified. The end connections must be made using XLR type 3 or 5-pin male/female connectors. A terminating plug must be inserted into the last projector with a resistance of 120 Ohm (minimum 1/4 W) between terminals 2 and 3.

IMPORTANT: The wires must not make contact with each other or with the metal casing of the connectors. The casing itself must be connected to the shield braid and to pin 1 of the connectors.

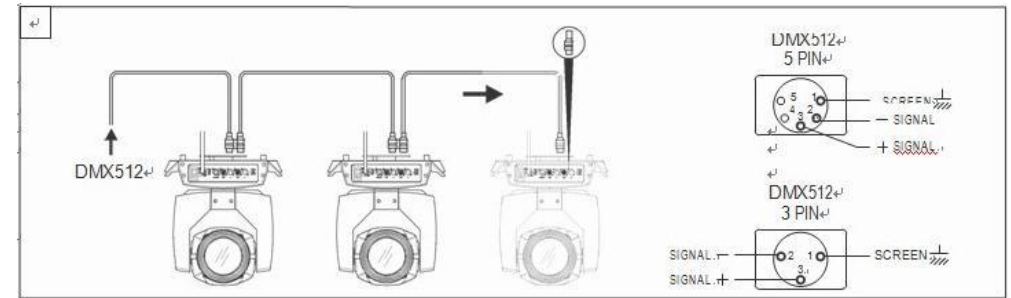

Figure 1 DMX Cable connection

19

- Product Size: 523×337×511mm
- Packing Size: 635X440X725
- Net weight: 19.5KG

1.6 Rigging (Optional)

This equipment can be positioned and fixed by clamp in every direction of the stage.

Locking system makes it easy to fasten to the bracket.

Attention! Two clamps is needed to fix the equipment. Every clamp is locked by fastener of 1/4 kind. Fastener can only be locked clockwise.

Attention! Fasten a safety string to the additional hole of side aluminum piece. The secondary accessory can not hang on the delivery handle. Nip the equipment on bracket.

- Check if rigging clamp (not including the one inside) damaged or not? If stand ten times weight as the equipment. Make sure the architecture can stand ten times weight as all the equipments, clamps, wirings and other additional fixtures.
- Screws for clamping must be fixed firmly. Take one M12 screw (Grade 8.8 or higher) to clamp bracket, and then screw the nuts.
- Level the two hanging points at the bottom of clamp. Insert fastener to the bottom, lock the two levers by 1/4 rotating clockwise; then install another clamp.
- Install on safety string which stands at least ten times weight as equipment. Terminal of the accessory is designed for clamps.
- Make sure pan/tilt lock unlocked or not. Keep the distance more than 1M from equipment to flammable material or lighting source.

MODE	CH	NAME	Value	BRIEF
Sample 16CH	CH1	COLOR		Select color or mode--(See details: 4-2. COLOR)
	CH2	STROBE	0~3	Dark
			4~103	Strobe from slow to fast
			104~107	White
			108~207	Pulse strobe from slow to fast
			208~212	White
			213~251	Random strobe from slow to fast
			252~255	White
	CH3	DIMMING	000-255	dimming 0~100%
	CH4	GOBO	4.3	Select gobo--(See details: 4-3. GOBO)
	CH5	PRISM 1	0~63	White
			64-127	PRISM 1
			128-191	PRISM 2
			192-255	PRISM 3
	CH6	ROTATE PRISM	0~127	Angle 0~400
			128~190	Rotate forward (Fast -- slow)
191~192			Stop	
193~255			Rotate reverse (Slow -- fast)	

Chapter 3 Channel description

3.1Channel table Light support 2 DMX mode: 16ch (Sample)

and 20ch (extend), as shown in 错误! 未找到引用源。:

2.3.6 STAT-->Status: View status

Enter the page as shown in Figure 2

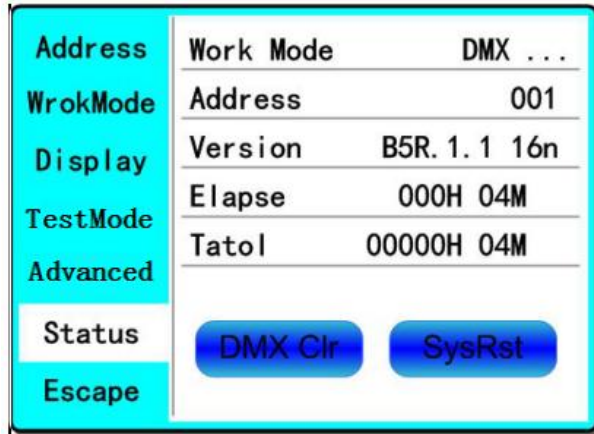

Figure 2 page of status

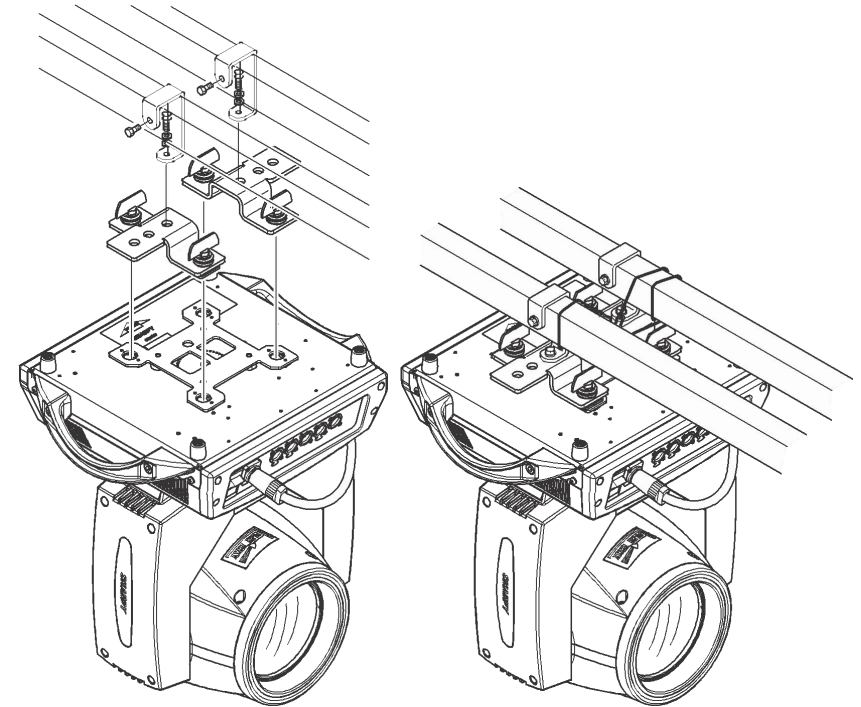

Figure 3 Installation

- ◆ **Work Mode:** Show the current working mode.
 - ◆ **Address:** Show the current address.
 - ◆ **Version:** Show the version of the lamp.
 - ◆ **Elapse:** Working hours after turn on.
 - ◆ **Tatol:** Cumulative hours of operation

When <Data hold> set <ON>,click to clear DMX data, and make the lamp return to themiddle position.

Click to reset.

Chapter 2 Panel operation

2.1 Brief

The light panel diagram show as Figure , Left area is TFT Displayer, support touch, and right area is KEY, both of touch and KEY can operate light and setting.

Display & operation just like 'Android operation system', touch the item will set or modify setting.

Note: Prevent damage the touch or TFT displayer, Can not use sharp objects chick displayer.

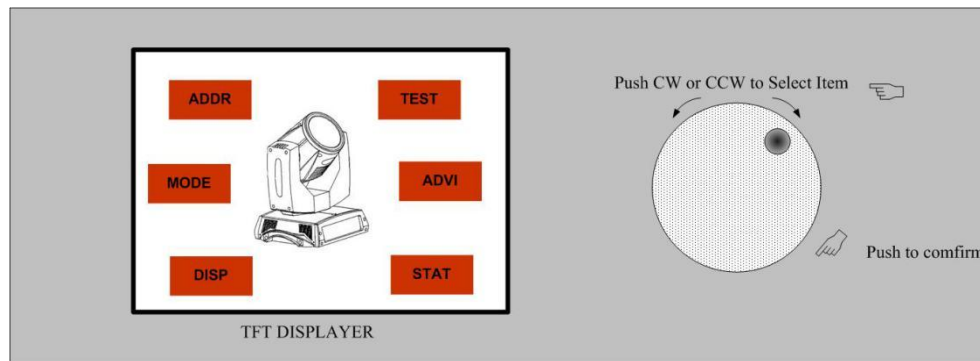

Figure 3 Panel diagram

- ◆ **Pan Invert:** Reverse PAN move
 - OFF--> Pan Normal move.(Default)
 - ON--> Reverse PAN move.
- ◆ **Tilt Invert:** Reverse TILT move
 - OFF--> Tilt Normal move.(Default)
 - ON--> Reverse Tilt move.
- ◆ **P/T Rectify:** Disable or enable position rectify function.
 - OFF--> Disable P/T rectify
 - ON--> Enable P/T rectify-(Default)
- ◆ **Pan Offset:** Set PAN original position. **Default: 10**
- ◆ **Tilt Offset:** Set TILT original position. **Default: 10**
- ◆ **Lamp when:**
 - PowerON--> Turn on the lamp when power on.(Default)
 - RstDone--> Turn on the lamp after reset.
 - Manual--> Manually turn on the lamp.
- ◆ **Data hold:**
 - OFF--> When no DMX signal,return to middle position.(Default)
 - ON--> When no DMX signal,stop in the final position.
- ◆ **Factory Setting:** Restore all parameter to factory setting.

- ◆ **PAN:** range for 0 to 255;
- ◆ **TILT:** range for 0 to 255;
- ◆ **FOCUS:** range for 0 to 255;
- ◆ **COLOR:** range for 0 to 255;
- ◆ **GOBO:** range for 0 to 255;
- ◆ **PRISM:** range for 0 to 255;
- ◆ **FROST:** range for 0 to 255;
- ◆ **STROBE:** range for 0 to 255;

2.3.5 ADVA-->Advanced: Set light run parameter

Enter the page as shown in Figure 7, set the parameter of light:

Address	PAN Inset	OFF
WorkMode	TILT Inset	OFF
Display	P/T Rectify	ON
TestMode	PAN Offset	010
Advanced	TILT Offset	010
Status	Lamp when	Power ON
Escape	Data hold	OFF
	Factory Setting	

Figure 4 page of run parameter

2.2 Operation

2.2.1 Operate light with touch or KEY

- The left area is TFT Displayer and touch, click item or value with finger will to complete operation of set light setting(parameters) or view light state.
- The area on the right hand side is 4 KEY, As auxiliary input interface, if disable touch function,, the KEYr can be choose to set the parameter.

2.2.2 Parameter value setting

When the selected item is value need to been modified, the dialog shown in Figure 5 will popup.

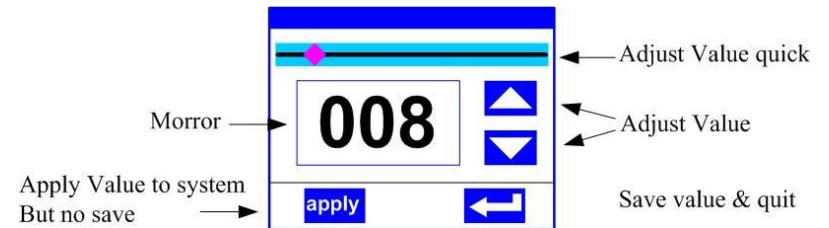

Figure 5 Dialog of value setting

- **Modify value:** Can quickly modify value via pull the slider to the desired position, or click the button of 'up' or 'down' with finger on the right side to set the exact desired value, another way is roll encoder on the right hand side of panel.

- **Apply value:** When Value had been modified, Then press the bottom of 'apply' in the left corner to apply to the light, but hav't saved;
- **Save Value :** Any time, click on the lower right corner of the "OK" button, the setting will been saved into internal memory.

2.2.3 Boolean parameter setting

- when the selected parameters is a Boolean value (such as ON or OFF), can directly modify setting by chick corresponding item, the setting will been saved right now.
- When the parameter is a key item, chick corresponding item, a dialog shown in Figure 6 will been popup ask for the confirm. Chick 'sure' to confirm.

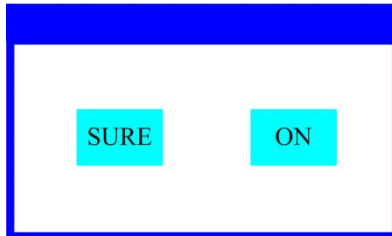

Figure 6 Dialog of confirm

2.2.4 Sub Menu (Parameter)

Chick item of main menu, enter corresponding sub menu, shown in Figure 9, total 6 sub menu, includes class of parameter and status:

- **ADDRESS:** Set light DMX address.
- **WORKMOD:** Set light work mode, master or slave mode when in auto run mode.
- **DISPLAY:** Set display parameter, eg. select language.
- **TEST :** Used for test light, modify DMX channel data to test function , the corresponding function of reference channel function table.

- ◆ **Screen Rotion: To turning display.**
ON--> Normal display.(Default)
OFF--> 180° turning display.
- ◆ **Touch enable:** Disable or enable touch function.,
ON--> Enable touch function.(Default)
OFF--> Dosable touch function.
- ◆ **Touch adjust:** Adjust touch function. Normally, not enter this item.

2.3.4 TEST--> TestMode

Enter the page as shown in Figure 7, Light will into test mode, in this mode, the light does not receive the data for DMX controller.:

Address	PAN	000
WorkMode	TILT	000
Display	FOCUS	000
TestMode	COLOR	000
	GOBO	000
Advanced	PRISM	000
Status	FROST	000
Escape	STROBE	000

Figure 7 page of Test

Channel Qty: Light support 2 DMX Channel mode: sample or extend。
 Simple --> 16CH.(Default)
 Expand--> 20CH(or null).

2.3.3 DISP-->DISPLAY: Set display

Light support 2 language, rotation display , Enter page as shown in Figure8 to set parameter following:

Address	语言	English
WorkMode	Screen saver	Mode3
Display	Screen rotation	OFF
TestMode	Touch Enable	ON
Advanced	Touch Rectify	
Status		
Escape		

Figure8 page of display

Language: English / 中文.

◆ **Screen Saver:** when panel is idle(these is no operation in 10 second), displayer will enter saver status.

OFF--> No screen saver.

Mode1--> Power-saving mode, turn off the display.

Mode2--> Displays the current address.

Mode3--> Displays the icon and the current working mode.(Default)

- ADVANCE: Set light running parameter.
- STATUS: view light current status.

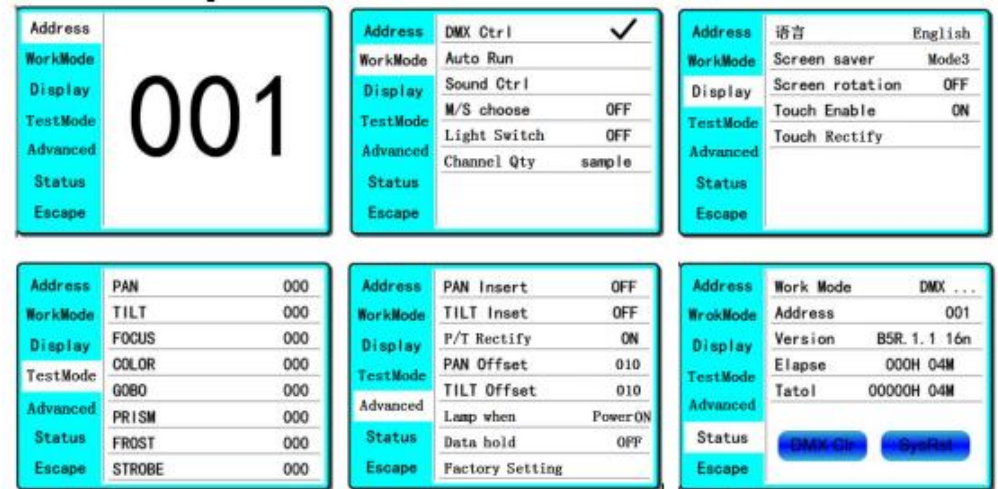

Figure 9 Parameter menu

2.3 Operation and parameter instruction

Via following operation, enter sub menu(parameter menu) shown in Figure 9

- In main menu, chik 1/6 function button into corresponding parameter menu.
- In sub menu(page), chik main item on the left side of displayer, can shift to corresponding sub menu(page) quickly.

2.3.1 ADDR--> Address: Set DMX Address

Click and select the "ADDR", can enter the page of DMX address setting, range from 1 to 512, the address code shouldn't is not greater than (512- channels quantity), otherwise the light will not been controlled. Following is the operation:

Enter the page of DMX address, as shown in Figure 10, click the blank area in right side of display will pop-up diglog as in Fig. 4, modify value, then click 'ENTER' to confirm and save DMX address code.

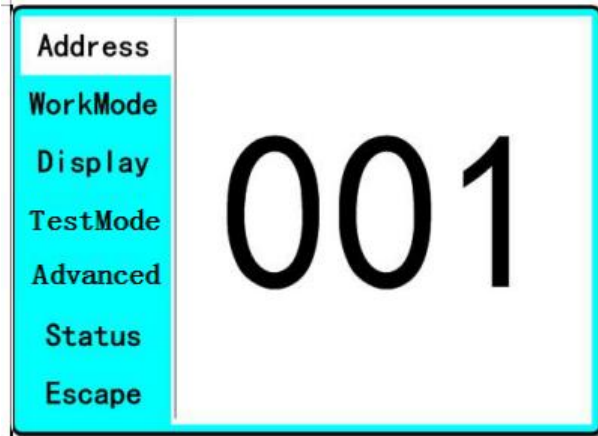

Figure 10 page of DMX Address

2.3.2 MODE--> WorkMode: Set Light work mode

Enter the page of 'WorkMode' as shown in Figure 11 and modify setting. Can set light work mode, control lamp and DMX channel mode.

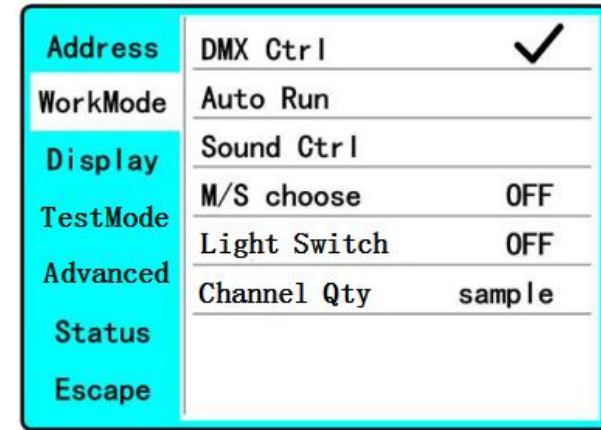

Figure 11 page of work mode

DMX Ctrl: Choose to set DMX Mode,

◆ **Auto Run:** Choose to set Auto Mode,

◆ **Sound Ctrl:** Choose to set Sound Mode,

◆ **M/S Choose:** Available just in 'AUTO RUN' or 'SOUND Ctrl' mode.

ON--> Master. (Data will be send to other slave lamp immediately.)

OFF--> Slaver.(NOT send data to other lamp via DMX Cable).(Default)

◆ **Light Switch:**

ON--> Turn on the light,

OFF--> Turn off the light.