





# DMX512 Timing Relay Pack +Smart Switch



User Manual V1.0

## Catalog

一) Product Introduction:	3
二) Achievable Function Introduction:	3
1) DMX512 Timing Relay Pack Function:	3
2) Smart Switch Function:	3
3) DMX512 Timing Relay Pack+Smart Switch:	3
三) Typical application:	4
1) Audio system power management:	4
2) Power management of lighting equipment (or other batch equipment):	4
四) Key points:	5
1) Application of multiple dmx512 timing relay pack to realize coordinated work:	5
2) Application of locking DMX512 signal function:	5
五) Technical parameter	6
六) Panel / rear panel introduction	7
七) Introduction to key operation	8
Table1 - Key icon description	8
1)  Key Function:	8
2)  and  Key Function:	8
3)  Key Function:	8
4) How to restore the product to the default parameters:	8
5) When the "start delay" is set too long, it takes a long time to enter the menu interface. How to cancel the current delay so that you can quickly enter the menu:	9
八) Menu expansion and description	9
1) Operation mode setting:	9
2) Delay time value setting:	9
3) Manual timing function setting:	10
4) DMX512parameter setting:	10
5) RS485 Serial code editing:	11
5-1) Code baud rate setting:	11
5-2) Code and edit operation:	11
九) Introduction to channel mode in DMX512 mode:	15
十) System built-in serial port code	18

## 一) Product Introduction:

"DMX512 Timing Relay Pack+Smart Switch" is a new power management product. It combines the function of timing device and intelligent switch control function, and supports a variety of control modes. Through the different combination of timing function and intelligent switch function, it can meet a variety of field application requirements.

## 二) Achievable Function Introduction:

### 1) DMX512 Timing Relay Pack Function:

【When  Delay-> Timing the delay value is on (the time value is not 0), it can be set to use the pure sequencer function】

- ◆ When the operation mode is set to manual mode  Mode-> Manual, It is a standard manual power DMX512 Timing Relay Pack product, which can realize the control function of the DMX512 Timing Relay Pack through the panel switch;
- ◆ When the operation mode is set to dmx mode  Mode-> Dmx, When it is channel mode  Dmx512-> Channel-> 02CH, It can realize the remote DMX512 Timing Relay Pack function through DMX512 signal;
- ◆ When the operation mode is set to code mode  Mode-> Code, The remote DMX512 Timing Relay Pack control function can be carried out through the 485 signal of the central control equipment;

### 2) Smart Switch Function:

【When  Delay-> Timing the delay value is off (the time value is 0), it can be set as a pure intelligent switch function】

- ◆ When the operation mode is set to dmx mode  Mode-> Dmx, set up channel mode to  Dmx512-> Channel-> 08CH 或  Dmx512-> Channel-> 10CH, Each switch can be remotely controlled by DMX512 signal;
- ◆ When the operation mode is set to code mode  Mode-> Code, Each switch can be remotely controlled through 485 signal of central control equipment;

### 3) DMX512 Timing Relay Pack+Smart Switch:

【When  Delay-> Timing the delay value is turned on (the time value is not 0), it can be set as an intelligent switch product with timing device function】

- ◆ When the operation mode is set to dmx mode  Mode-> Dmx, set up channel mode to  Dmx512-> Channel-> 10CH, The DMX512 signal can be used to realize the remote timing

switch operation of multi-channel equipment, and each switch can also be remotely controlled;

◆ When the operation mode is set to code mode `[Mode]`->`[Code]`, Remote sequential switch operation can be carried out through 485 signal multi-channel equipment of central control equipment, and each switch can also be remotely controlled;

## 三) Typical application:

### 1) Audio system power management:

◆ The equipment of the sound system has strict sequence requirements for the opening of the power supply. If the power supply of the equipment is not turned on and off in the normal sequence, it will cause a strong noise signal to be introduced into the power amplifier. After amplification, it will produce a harsh sound. When the current is large enough, the sound equipment may be burned.

◆ If the equipment current is closed directly through the main gate, all equipment will be powered on at the same time, resulting in the superposition of current, which will produce a strong instantaneous current, and the impact caused by the current may damage the equipment.

◆ At the same time, because the equipment supports remote timing control function, it can realize remote power control of sound system in combination with light console or central control equipment.

### 2) Power management of lighting equipment (or other batch equipment):

◆ entertainment lighting facilities are generally used in a large number (typical batch equipment application scenarios). If these devices are controlled only through the main gate at the same time, it will cause a large current impact. This impact current may damage the lighting equipment or control system, and in serious cases, it may cause the paralysis of the whole system. If the sequential power supply equipment is added to the lighting system, the equipment damage caused by current impact will be avoided.

◆ at the same time, in the era of intelligent control, both lighting effect and power supply need remote control. The device also provides a solution for remote control of each switch, which can realize remote power management and control.

### 3) Places requiring intelligent power supply control:

Many devices such as smart hotels, smart homes, smart conference rooms and so on do not support remote signal control. The remote control function of these devices can be realized through the smart switch function to make non smart devices intelligent.

## 四) Key points:

### 1) Application of multiple dmx512 timing relay pack to realize coordinated work:

When the number of output channels of the dmx512 timing relay pack exceeds 8, multiple dmx512 timing relay pack devices can be used for coordination. When multiple sets are used, it is unnecessary to realize coordination through signals. The staggered peak start is realized by setting a start waiting time value  $\boxed{\text{Delay}} \rightarrow \boxed{\text{Start}}$  for the later dmx512 timing relay pack.

**The setting method is as follows:**

For example, 3 dmx512 timing relay pack products are used to coordinate the work to form a 24 channel timing effect.

**Operation method:**

- a, a. First, set the delay value of the three time dmx512 timing relay packs, and set the delay value  $\boxed{\text{Delay}} \rightarrow \boxed{\text{Timing}}$  to 1 second (the time size can be set as required). Since the equipment has 8 outputs, the working time of each equipment is  $8 * 1 \text{ second} = 8 \text{ seconds}$ .

The total time of the dmx512 timing relay pack is calculated as follows:

$$\text{The total time of dmx512 timing relay pack } n = \boxed{\text{Delay}} \rightarrow \boxed{\text{Start}} + \boxed{\text{Delay}} \rightarrow \boxed{\text{Timing}}$$

- b, Set the startup waiting time value of each product  $\boxed{\text{Delay}} \rightarrow \boxed{\text{Start}}$ :  
dmx512 timing relay pack1  $\boxed{\text{Delay}} \rightarrow \boxed{\text{Start}}$  value = 0Second;  
dmx512 timing relay pack2  $\boxed{\text{Delay}} \rightarrow \boxed{\text{Start}}$  value  $\geq$  Total time of dmx512 timing relay pack1 (the setting value should be greater than this time value);  
dmx512 timing relay pack3  $\boxed{\text{Delay}} \rightarrow \boxed{\text{Start}}$  value  $\geq$  Total time of dmx512 timing relay pack2 (the setting value should be greater than this time value);  
And so on.....

- c. After setting the time according to the above parameters, starting the three products at the same time can produce the effect of timing coordination.

### 2) Application of locking DMX512 signal function:

When the light console restarts and other operations, it will output DMX512 signal with

full 0 value, which will cause the general dmx512 timing relay pack equipment or intelligent switching equipment to perform the action of turning off the power supply output, resulting in abnormal power failure of the original normal power supply equipment.

In order to avoid this phenomenon, CP0802 dmx512 timing relay pack + smart switch gear provides a locking solution in DMX512 mode, and the corresponding channel mode can be selected as needed:

◆ 2channel mode [Dmx512]->[Channel]->[02CH] is DMX512 remote pure sequencer control with locking function;

◆ 8channel mode [Dmx512]->[Channel]->[08CH] is DMX512 信 Pure intelligent switch control without locking function;

◆ 10channel mode [Dmx512]->[Channel]->[10CH] is DMX512Signal remote Sequencer with locking function +smart switch control; if close delay value [Delay]->[Timing] this mode is DMX512Pure intelligent switch control mode with signal locking.

## 五) Technical parameter

Type	Parameter	illustration
Maximum current of input line with plug	25A	Optional when ordering
Maximum current of bare input line	40A	Optional when ordering
Input Voltage	90-240V/50-60Hz	Full frequency voltage input, universal
Rated output power of each circuit	1000W	
Dmx512 timing replay pack function	Have	
Smart switch function	Have	
Manual mode	Support	
DMX512signal control mode	Support	
Channel mode supported by DMX512 mode	2/8/10ch	Different channel modes different purposes
RS485signal control mode	Support	
Power output base	Universal power base (default)	Other types of seats need to be explained when ordering
Installation dimension	Standard 19 inch 1U cabinet	
Installation mode	3 kinds (cabinet, lamp hook, screw fixation)	

## 六) Panel / rear panel introduction

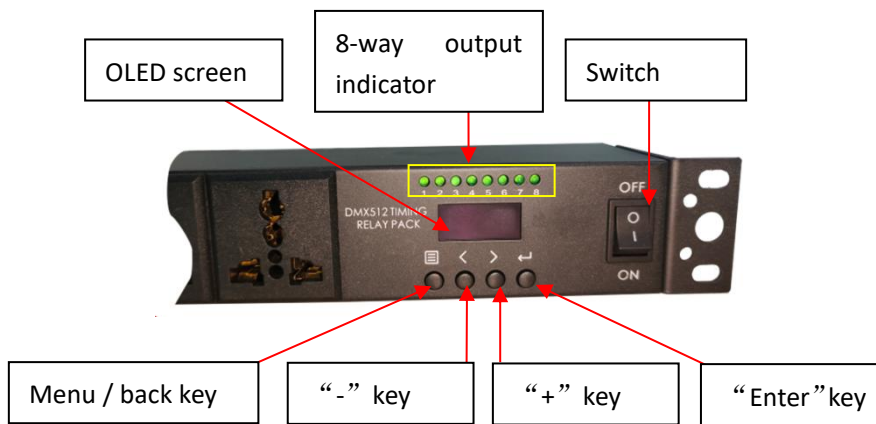
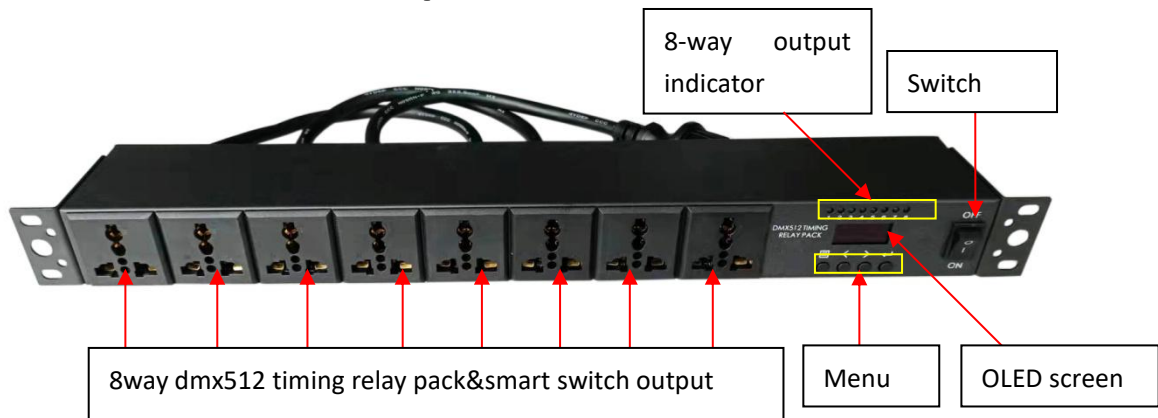

## 七) Introduction to key operation

Table1 - Key icon description

Key Icon				
Function description	<b>[MENU]</b> Menu (back)	<b>[DOWN]</b> <b>Minus</b>	<b>[UP]</b> Plus	<b>[ENTER]</b> Enter(save,clear)

### 1) Key Function:

Press this key to return to the previous menu. If the current modified content is not saved, the modified content will be cleared when returning to the previous menu;



### 2) and Key Function:

- a) In the non end level menu, it can be used to select the menu item to be operated;
- b) In the last level menu, it can be used to select specific parameters and input parameter values;

### 3) Key Function:

- a) In the non end level menu, short press this key to enter the lower menu of the current menu item;
- b) In the parameter input state, long press this key to clear the current parameter value (i.e. restore to the default value);

### 4) How to restore the product to the default parameters:

Long press  and  3 second at the same time , All parameters of the product will be restored to the default value; The RS485 serial port control code will be restored to the built-in serial port code of the system (see Table 6 for the content of the control code)



## 5) When the "start delay" is set too long, it takes a long time to enter the menu interface. How to cancel the current delay so that you can quickly enter the menu:

Long press  key 3 second, Directly exit the current "start waiting delay" process, but it does not affect the parameter value.

## 八) Menu expansion and description

### 1) Operation mode setting:

3 operation modes selection: When select Mode:<Dmx>, set to DMX512signal control mode; When select Mode:<Code>, Set to RS485 signal control mode of central control equipment; When select Mode:<Manual>, set to manual dmx512 timing relay pack mode, It is controlled by the timing switch and Manual->Port menu parameters of the panel.

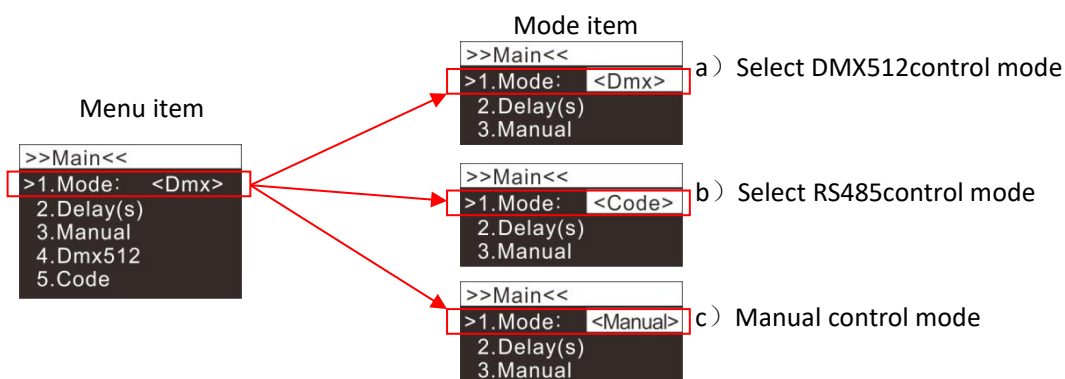

### 2) Delay time value setting:

◆ If the manual timing or RS485 timing function needs to be turned on or off, it can be completed by setting the time value of Delay(s)->Timing parameter (the integer part of the time value is in seconds). When the time value is set to 0, it means that the timing function is turned off;

◆ If you need to use multiple sequencer devices to expand the timing output circuit, you can insert a start waiting delay value by setting the Delay(s)->Start parameter to expand the output circuit (see: multiple sequencers realize coordinated work application);

◆ If you need to delay the power-off of the equipment itself, you can set the Delay(s)->End parameter to generate a power-off delay. The minimum time value is 0.5 seconds.

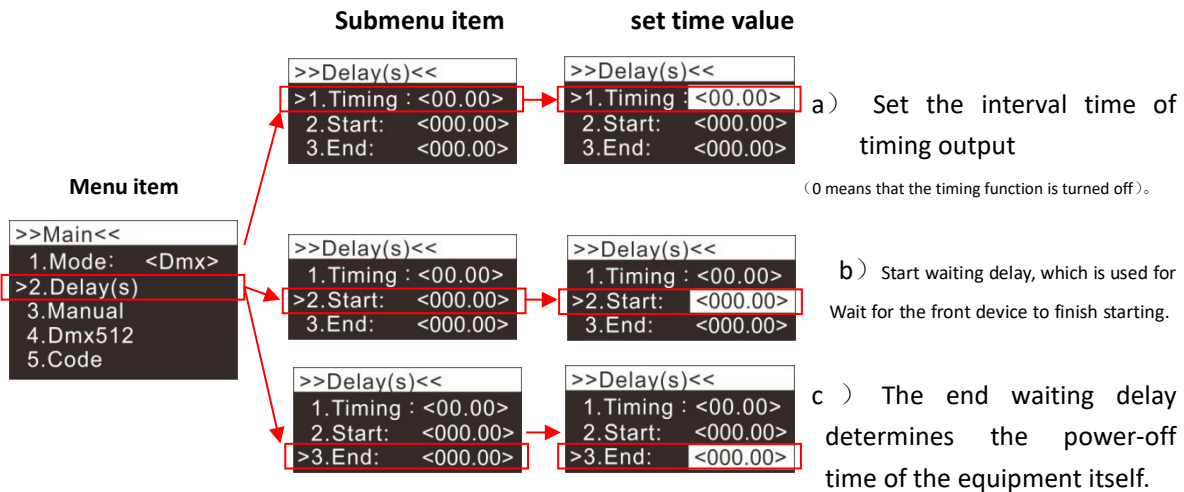

### 3) Manual timing function setting:

◆ When the product is operated manually, that is, in the mode: < manual > operation mode (see: operation mode setting), the output status of the port can be controlled by selecting the output port number and output status value in the **Manual**->**Port** menu item; In this parameter, for example: <1:On> content, the number in angle brackets < > indicates the output port number, and the following English on indicates on and off indicates off;

◆ If you want to shield some ports (so that they do not participate in timing output), set the port to off state and save it. At this time, the timing switch on the panel will not control the output of the port.

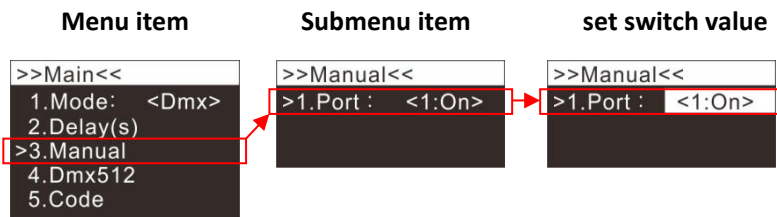

Output or shielding control of panel output port. The value in < > indicates the panel output Port serial number, English content indicates switch Status, such as 1 in < 1: on >Port 1, on is on and off is off.

### 4) DMX512 parameter setting:

◆ When the product is under DMX512 signal control, i.e. in Mode: < DMX > operation mode (see: operation mode setting),

**Dmx512**->**1.Address** parameter is used to set the DMX512 address. The value range of the address value is 1-512;

◆ Setting of DMX512 channel mode: **Dmx512**->**2.Channel** parameter is used to select the

channel mode under DMX512 mode (for the specific content of channel mode, see: introduction to channel mode under DMX512 operation mode). There are three channel modes available: 02ch (2-channel mode), 08ch (8-channel mode) and 10Ch (10-channel mode).

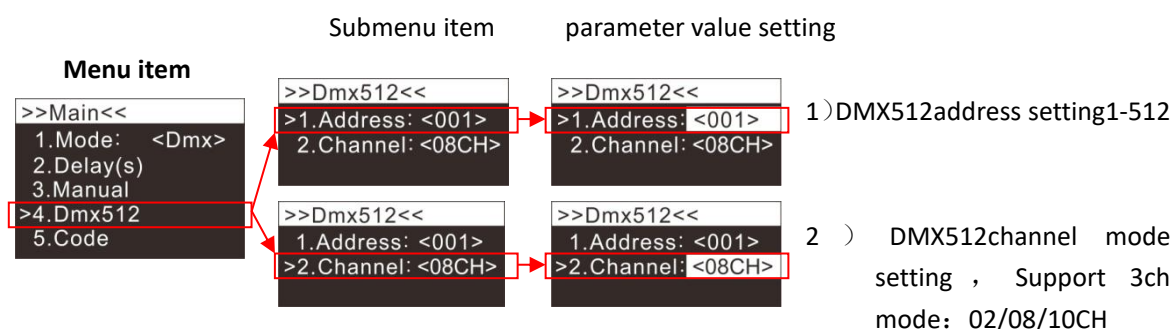

## 5) RS485 Serial code editing:

◆If the system integration is to be realized, the panel control can trigger the operation of the equipment through the RS485 signal of the central control equipment.

### 5-1) Code baud rate setting:

#### ◆Baud rate setting

When the product is controlled by RS485 signal, i.e. in mode: < code > operation mode (see: operation mode setting), **Code**->**Buad** parameter is used to select the working baud rate of the equipment. The baud rate must be the same as that of the central control equipment to work normally;

#### ◆Baud rate setting menu expanded

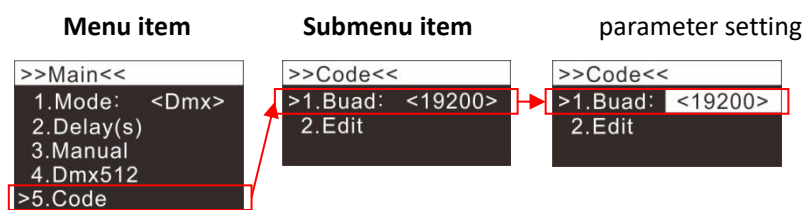

### 5-2) Code and edit operation:

◆ **Code**->**Edit** Parameters are used to set the contents of the docking control command between the central control equipment and the equipment:

◆Description of the storage space of the control code of the sequential intelligent switch product:

The product has eight output ports, each port can store up to eight groups of

control codes, and each group of control codes can store one "on" code and one "off" code.

Eight groups of "all" codes are also provided. Each group of "all" codes also includes an "on" code and an "off" code. The main control code is valid for all ports.

When the control code of a port is the same as the "all" code, the "all" code will be run first, and the port code will be ignored.

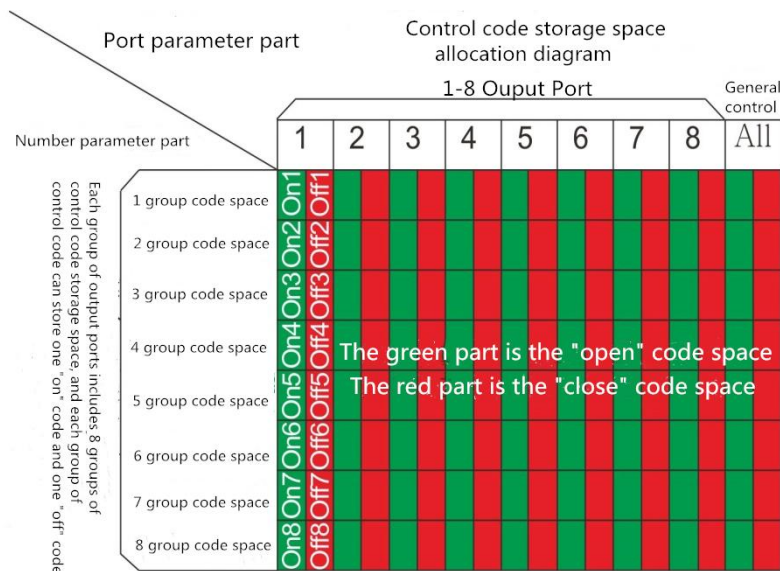

The feature of supporting simultaneous control of multiple control codes provides more flexibility and practicability for applications

- 1) Grouping control can be realized, and any combination control can be carried out for 8-channel output;
- 2) Sequential and non sequential control;

3) Multi code simultaneous control can be realized.

◆ Code->Edit->xxxx->Port 和 Code->Edit->xxxx->Number Parameter content description:  
menu name Code->Edit->xxxx refer to : Code->Edit->Load、Code->Edit->Save and Code->Edit->Delete 3 item menu, All three menus contain Port 和 Number parameter, It has the same meaning.

a) Port Parameters are used to select the output port number and output status of the port:

Port: < 1 : On >

Value illustration	Output Port
All	Port No.
1	Port1
2	Port2
3	Port3
4	Port4
5	Port5
6	Port6
7	Port7
8	Port8

Value illustration	Output status value
On	On
Off	Off

▲ In the "< >" angle brackets of the parameter, ":" The part before the colon indicates the output "port number" (such as "1" mean "port 1").

▲ When port number select "All", Indicates that the control code is valid for all ports. At this time, if the delay value is set, the timing switch function can be realized through RS485 signal;

▲ ":" The part after the colon is the port "on" and "off" status setting ("on" is on and "off" is off),

▲ If you want to use the same group of control codes to control the output of a port in a flip mode, you only need to store the group of control codes in the "on" state for a port and then in the "off" state for a port to realize the flip control of a port.

b) **Number** Parameter is used to specify the location of the control code or the location you want to store.

Number: < 1 : - - >

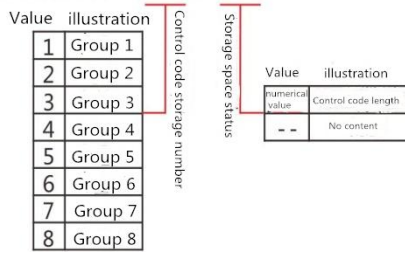

▲ “<>” In angle brackets, “:” The content in front of the colon indicates the serial number of the storage space (1-8 optional);

▲ “:” The content after the colon indicates the length of the control code stored in the current space, which is represented by a two digit (hexadecimal) value. If the content is displayed as a “-” value, it indicates that the space content is empty.

◆Expand the control code edit menu:

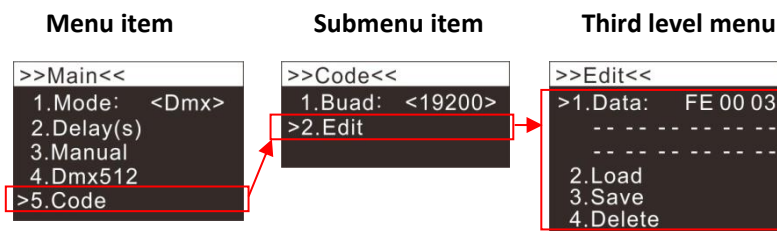

## 5-2.1) Control code editing:

◆To edit the content of the control code, there will be 15 data contents after the **Code->Edit->Data** parameter (these data are hexadecimal contents, and each data occupies two characters). There are two ways to input and edit the content of the control code:

Method 1: (learning method) as long as the central control device sends the control code to the device, the device will display the control code in the **Code->Edit->Data** parameter table after receiving the control code. We can save the control code to the corresponding port and complete the control code editing;

◆The control code content (input method) editing operation menu is expanded:

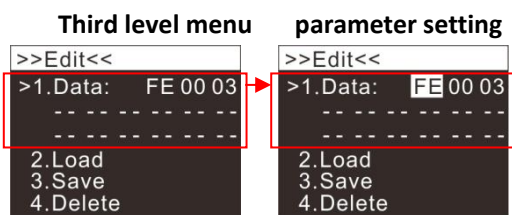

a) In the data table, the valid contents are displayed in hexadecimal values, and the invalid contents are displayed --, and up to 15 control code contents are supported;

b) key can select each specific data in the data table;

c) and key can enter the value of the selected data.

## 5-2.2) Control code saving:

◆To save the content of the control code, `Code->Edit->Save` parameter is used to assign `Code->Edit->Data` control code data to a port and assign the output status to the port.

◆ `Code->Edit->Save->Port` Parameter specifies the port number and the output status of the port (This parameter is described by reference: Code Edit operation), When the enter key  is pressed at the parameter position to save, the equipment will automatically find an empty storage position to save the content of the control code;

◆ `Code->Edit->Save->Number` Parameter specifies the storage location of the control code (This parameter is described by reference: Code Edit operation), When you press the enter key  to save in the position of `Code->Edit->Save->Number` parameter, the device will save the current control code according to the storage location specified by the number parameter. If there is content in the specified location, it will be replaced with the content of the current control code; For example, when the parameter value is "Number: < 2: -- >", the control code is saved in storage space 2.

◆Expand the control code saving operation menu:

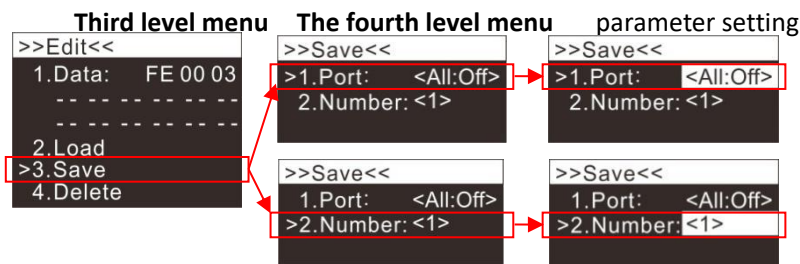

## 5-2.3) Control code loading (read / view):

◆Loading the existing control code content. `Code->Edit->Load` parameter is used to load the existing control code content into `Code->Edit->Data` control code data area for easy viewing and modification. It can also be saved as the control code of other ports;

◆ `Code->Edit->Load->Number` Parameter select which group of control codes in the port number to load (refer to code edit for parameter description);

◆ After pressing the Enter key , the control code will be displayed in `Code->Edit->Data` control code data area.

◆Control code loading (read / view) operation menu expansion:

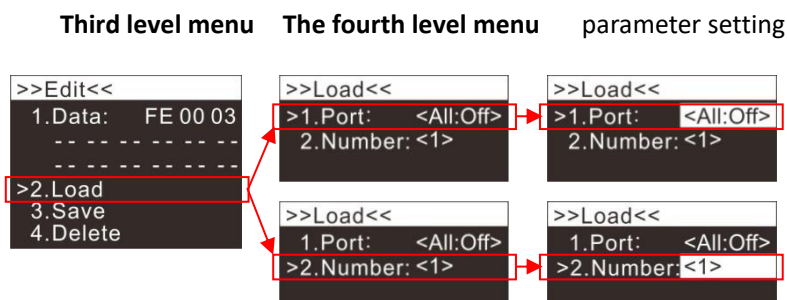

## 5-2.4) Control code deletion:

◆ Delete control code content, **Code->Edit->Delete** Parameter is used to delete the existing control code.

◆ **Code->Edit->Delete->Port** The parameter selects the port number to be deleted and the corresponding output status (for the parameter description, refer to code code edit operation). When you press the enter key  at the parameter position to delete, the equipment will delete all the control code contents of the port pointing to the output status; For example, when the port number is selected as the value of "port: < 1: on >", all the control codes in "on" status in "port 1" will be deleted;

◆ **Code->Edit->Save->Number** The parameter selects which group of control codes in the port number to delete (the parameter description refers to the edit operation of code code code). When pressing the enter key  to delete in the parameter position, the device will delete the control code according to the storage location specified by the number parameter. For example, when the parameter value is "Number: < 5:03 >", the control code in the storage space No. 5 of the current port will be deleted.

◆ Expand the control code deletion operation menu:

**Third level menu      The fourth level menu parameter setting**

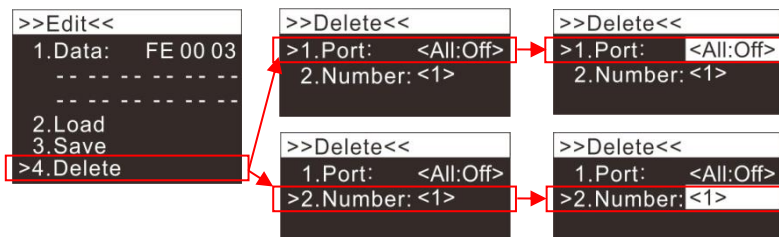

## 九) Introduction to channel mode in DMX512 mode:

Table 2) functions corresponding to each channel in three channel modes:

8channel mode (channel number)	2channel mode (channel number)	10channel mode (channel number)	Function name corresponding to the channel
--	1	1	General control
	2	2	Sequencer time
1	--	3	Switch 1
2		4	Switch 2
3		5	Switch 3

4		6	Switch 4
5		7	Switch 5
6		8	Switch 6
7		9	Switch 7
8		10	Switch 8

Table 3) function description of each channel under 2-channel mode (suitable for remote sequential power on and power off control):

Channel Number	Function Name	DMX value range		Function description
		Min	Max	
1	General control	0	7	Status hold (disable input of all channels)
		8	127	Main control switch (all closed)
		128	255	DMX master switch (permissive control) 8-way)
2	Sequencer time	0	7	Timing off (8-way switch timing function off)
		8	255	Timing time input (time range: 40ms-10s)

Table 4) function description of each channel under 8-channel mode (suitable for ordinary DMX switch control):

Channel Number	Function Name	DMX value range		Function description
		Min	Max	
1	Switch 1	0	127	Switch 1 is off (when "switch general permission" is valid)
		128	255	Switch 1 is on (when "switch general permission" is valid)
2	Switch 2	0	127	Switch 2 is off (when "switch general permission" is valid)
		128	255	Switch 2 is on (when "switch general permission" is valid)
3	Switch 3	0	127	Switch 3 is off (when "switch general permission" is valid)
		128	255	Switch 3 is on (when "switch general permission" is valid)
4	Switch 4	0	127	Switch 4 is off (when "switch general permission" is valid)
		128	255	Switch 4 is on (when "switch general permission" is valid)



5	Switch 5	0	127	Switch 5 is off (when "switch general permission" is valid)
		128	255	Switch 5 is on (when "switch general permission" is valid)
6	Switch 6	0	127	Switch 6 is off (when "switch general permission" is valid)
		128	255	Switch 6 is on (when "switch general permission" is valid)
7	Switch 7	0	127	Switch 7 is off (when "switch general permission" is valid)
		128	255	Switch 7 is on (when "switch general permission" is valid)
8	Switch 8	0	127	Switch 8 is off (when "switch general permission" is valid)
		128	255	Switch 8 is on (when "switch general permission" is valid)

Table 5) function description of each channel under 10 channel mode (suitable for remote sequential power on and power off, DMX intelligent switch control, keeping power supply undisturbed in case of DMX signal loss and recovery):

Channel Number	Function Name	DMX value range		Function description
		Min	Max	
1	General control	0	7	Status hold (disable input of all channels)
		8	127	Main control switch (all closed)
		128	255	Total switch allowed (8-way DMX switch control allowed)
2	Sequencer time	0	7	Timing off (8-way switch timing function off)
		8	255	Timing time input (time range: 40ms-10s)
3	Switch 1	0	127	Switch 1 is off (when "switch general permission" is valid)
		128	255	Switch 1 is on (when "switch general permission" is valid)
4	Switch 2	0	127	Switch 2 is off (when "switch general permission" is valid)
		128	255	Switch 2 is on (when "switch general permission" is valid)
5	Switch 3	0	127	Switch 3 is off (when "switch general permission" is valid)

		128	255	Switch 3 is on (when "switch general permission" is valid))
6	Switch 4	0	127	Switch 4 is off (when "switch general permission" is valid)
		128	255	Switch 4 is on (when "switch general permission" is valid)
7	Switch 5	0	127	Switch 5 is off (when "switch general permission" is valid))
		128	255	Switch 5 is on (when "switch general permission" is valid)
8	Switch 6	0	127	Switch 6 is off (when "switch general permission" is valid)
		128	255	Switch 6 is on (when "switch general permission" is valid)
9	Switch 7	0	127	Switch 7 is off (when "switch general permission" is valid)
		128	255	Switch 7 is on (when "switch general permission" is valid)
10	Switch 8	0	127	Switch 8 is off (when "switch general permission" is valid)
		128	255	Switch 8 is on (when "switch general permission" is valid))

## +) System built-in serial port code

Table 6) when restoring the default (i.e. restoring the factory setting) of the product, the RS485 serial port control code will be restored to the following table contents, and the central control equipment can directly send the following code to control the corresponding switch:

Control code (hexadecimal)	Number of valid bytes	Corresponding control port	Corresponding output status
FD 01 03	3	1	On
FC 01 03	3	1	Off
FD 02 03	3	2	On
FC 02 03	3	2	Off
FD 03 03	3	3	On
FC 03 03	3	3	Off
FD 04 03	3	4	On
FC 04 03	3	4	Off
FD 05 03	3	5	On
FC 05 03	3	5	Off
FD 06 03	3	6	On

FC 06 03	3	6	Off
FD 07 03	3	7	On
FC 07 03	3	7	Off
FD 08 03	3	8	On
FC 08 03	3	8	Off